

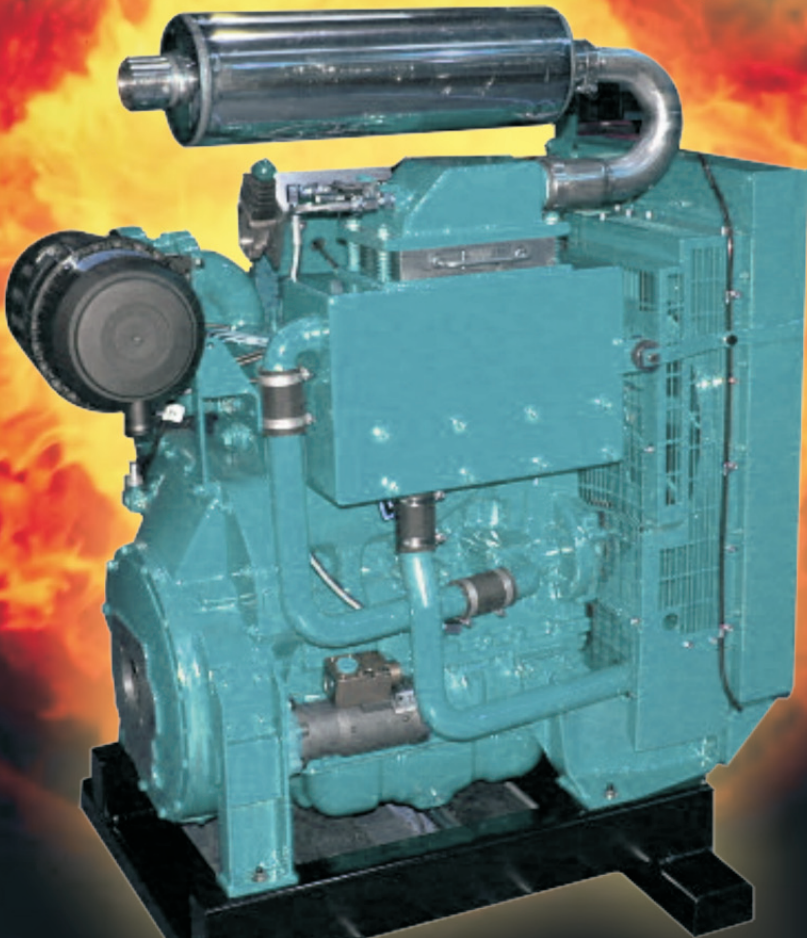

Quality Products for Mechanical
& Fluid Power

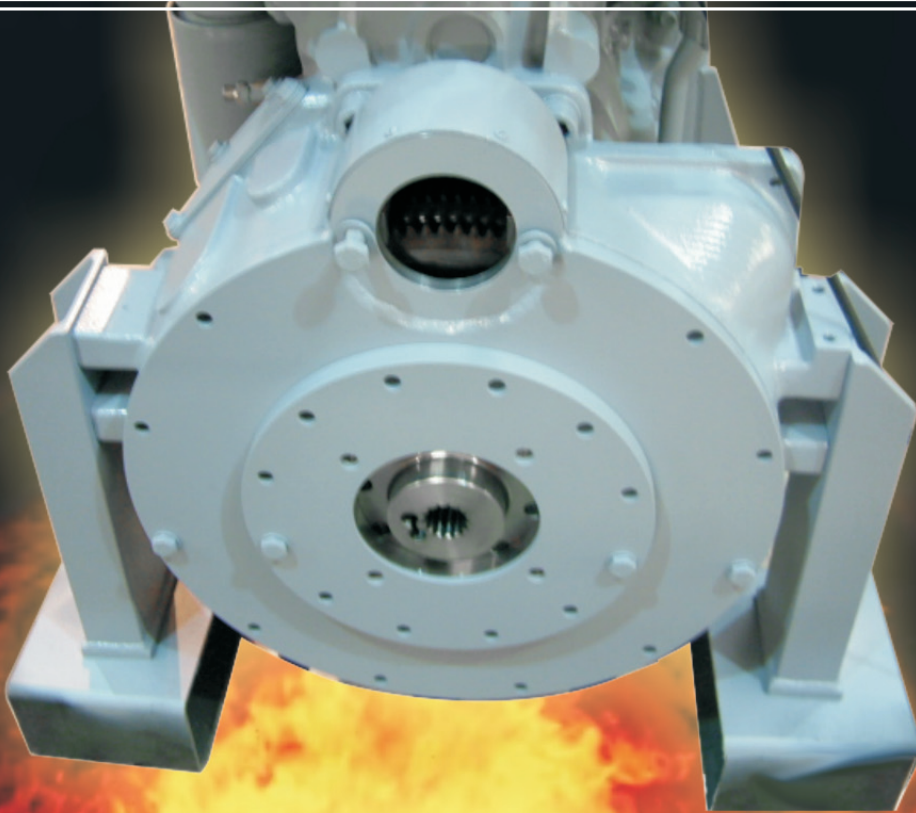
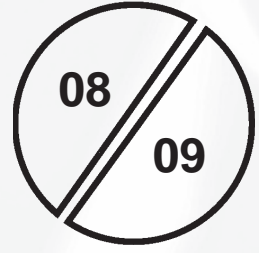

EQUIPMENT FOR HAZARDOUS AREAS

ENGINE BELLHOUSINGS & JXL ANTI-STATIC COUPLINGS

Installation & maintenance instructions





jbj Techniques Limited
 28 Trowers Way, Holmethorpe Industrial Estate
 Redhill, Surrey RH1 2LW United Kingdom
 telephone: 01737 767493 fax: 01737 772041 email: info@jbj.co.uk www.jbj.co.uk



EC Declaration of Conformity



jbj Techniques Limited of the address given above confirm that

Engine bellhousings and JXL anti-static flywheel couplings of serial number:

.....

have been produced in accordance with the requirements specified within

Directive

94/9/EC II2GD-IM2-T6

Harmonised Standards

EN13463-4 EN13463-5 EN50303 EN13463-1

Dossier receipt number: 03011304 Intertek Testing Services

for

Client:

Date:

Signed by Mike Davis (Managing Director)

Separation of this certificate from the remaining pages of this documentation will render it ineffective.

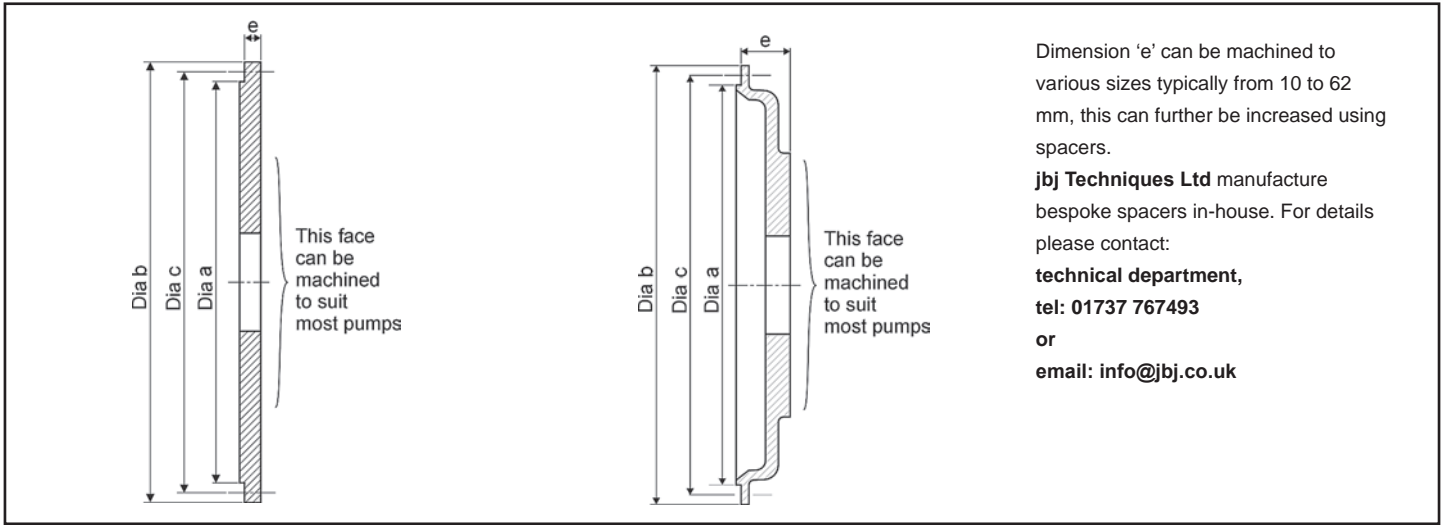

Dimension 'e' can be machined to various sizes typically from 10 to 62 mm, this can further be increased using spacers.

jbj Techniques Ltd manufacture bespoke spacers in-house. For details please contact:
technical department,
tel: 01737 767493
or
email: info@jbj.co.uk

Size	SAE 5	SAE 4	SAE 3	SAE 2	SAE 1	SAE 0
Dia. a	314.32	361.95	409.57	447.67	511.17	647.7
Dia. b	356.00	403.00	453.00	489.00	555.00	712.00
Dia. c x No. holes Dia. holes @ angle	333.38 x 8 Dia 11 x 45°	381.00 x 12 Dia 11 x 30°	428.62 x 12 Dia 11 x 30°	466.72 x 12 Dia 11 x 30°	530.22 x 12 Dia 12 x 30°	679.45 x 16 Dia 13.5 x 22.5°

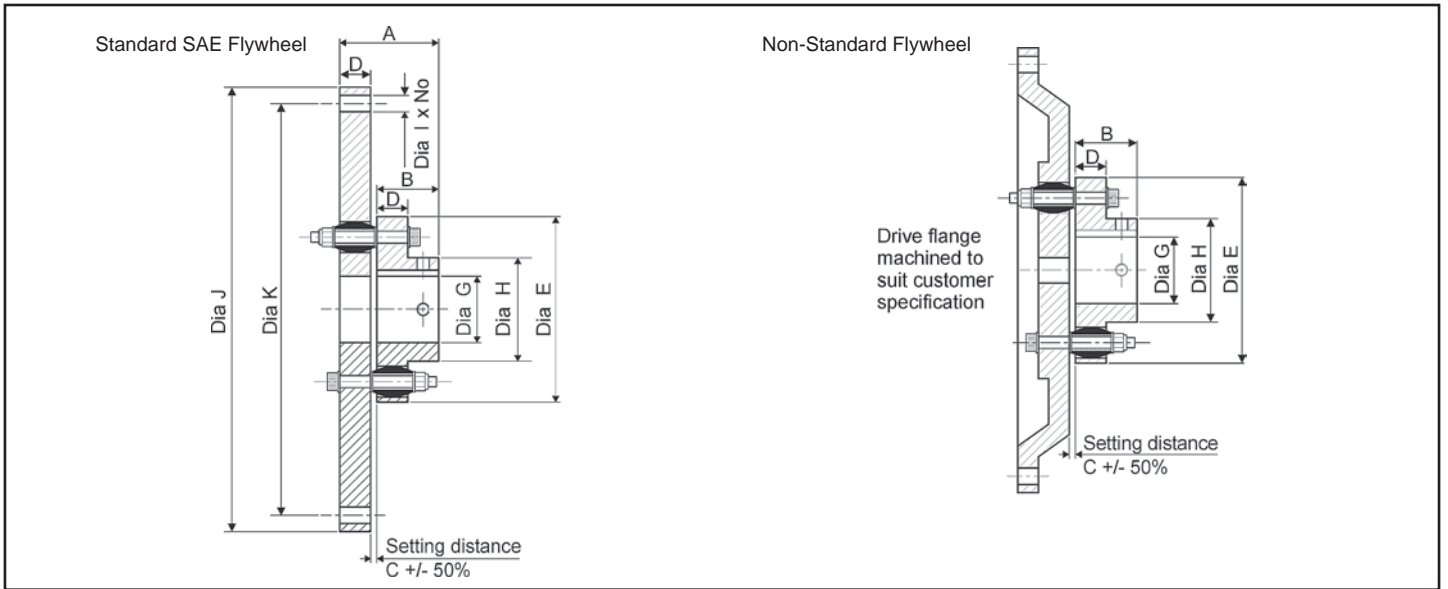

Type	6½"	7½"	8"	10"	11½"	14"	18"
J	215.90	241.30	263.52	314.32	352.42	466.72	571.5
K	200.02	222.25	244.47	295.27	333.37	438.15	542.93
l x n	9.0 x 6	9.0 x 8	11.0 x 6	11.0 x 8	11.0 x 8	13.0 x 8	17.0 x 6*

*Some flywheels may have 12 holes

Type	Minimum Bore G	Maximum Bore G	A	B	C	D	E	H
JXL 25	12	28	Dimensions A & B to suit application dependent upon engine SAE sizes		3	15	80	40
JXL 32	16	38			3	15	90	53
JXL 42	18	48			5	25	115	67
JXL 55	20	60			5	25	135	83
JXL 65	30	73			5	25	150	98
JXL 80	35	90			5	30	185	123
JXL 90	45	100			5	40	210	138
JXL 100	50	110			5	50	235	153
JXL 120	60	130			5	50	260	178



This guide is for the installation of JXL flywheel couplings when an engine bellhousing is used.

The coupling pins are tightened to the correct torque prior to leaving jbj Techniques Ltd; these values should be re-checked prior to installation. Under no circumstances should the couplings be assembled with the pins tightened to any torque other than the specified values.

Mounting

In most cases the diameter of the hub is smaller than the centre locating diameter of the bellhousing. The hub passes through the bore in the bellhousing which connects the pump with the flywheel housing. In this case the installation can be carried out as follows:

- 1) Fit the drive flange to the engine flywheel and tighten bolts to engine manufacturers recommendations.
- 2) Fit the bellhousing to the engine flywheel housing and tighten bolts to engine manufacturers recommendations.
- 3) Fit the pump centring to the pump (when supplied) then fit the coupling hub to the pump shaft, position the hub suitably to obtain the correct setting distance, (see arrangement drawing if supplied), tighten grub screw(s) or L-Lock screw(s) if the pump has a splined shaft, and re-check the setting distance. Coupling hubs with cylindrical bores are supplied with an additional grub screw at 90° to the keyway. If the additional grub screw is not to be used it must be removed from the coupling hub.
- 4) Fit the pump and coupling hub to the bellhousing ensuring that there is no loose matter i.e. grub screws, washers, etc. remaining inside the housing and that no rotating component is within 5 mm of any non rotating part.

For the occasional case where the hub diameter is larger than the bore in the bellhousing, the installation should be carried out as follows:

- 1) Fit the drive flange to the engine flywheel and tighten bolts to engine manufacturer's recommendations.
- 2) Fit the bellhousing to the pump.
- 3) Fit the coupling hub to the pump shaft, position the hub suitably to obtain the correct setting distance (see the arrangement drawing if supplied), tighten grub screw(s) or L-Lock screw(s) if the pump has a splined shaft and re-check the setting distance. Coupling hubs with cylindrical bores are supplied with an additional grub screw at 90° to the keyway. If the additional grub screw is not to be used it must be removed from the coupling hub.
- 4) Offer up the pump, coupling hub and bellhousing to the engine flywheel housing ensuring that there is no loose matter i.e. grub screws, washers, etc. remaining inside the housing and that no rotating component is within 5 mm of any rotating component, and tighten bolts to the engine manufacturer's recommendations.

Tighten all bolts to the correct torque values. We recommend the use of shake proof washers with all bolts.

Tightening Torques for JXL Resilient Couplings

Coupling Size	Screw Size	Tightening Torque		Coupling Size	Screw Size	Tightening Torque		 L-Lock Screws	
		Nm	lb/ft			Nm	lb/ft		
25	M5	5.08	3.75	148	M16	187.00	138.00		
32	M5	5.08	3.75	160	M16	187.00	138.00		
42	M6	9.20	6.80	170	M16	187.00	138.00		
55	M6	9.20	6.80	190	M20	337.00	249.00		
65	M6	9.20	6.80	210	M20	337.00	249.00		
80	M10	41.00	30.00	240	M24	568.00	419.00		
90	M10	41.00	30.00	270	M30	1144.00	835.00		
100	M12	77.00	57.00	300	M30	1144.00	835.00		
120	M12	77.00	57.00	340	M30	1144.00	835.00		
								Grub Screw	Torque N m
								M10	30
								M12	50
								M14	70
								M16	120
								M20	200

Axial Misalignment

All couplings plus or minus 50% of flange gap (dimension C) setting distance.

Periodically check flange alignment and resilient elements for wear. Worn elements must be replaced. Misalignment must be rectified.

Inspection and maintenance is the responsibility of the end user.

All JXL couplings are capable of accepting a momentary overload of twice nominal torque and have an operating temperature range of -50°C to +105°C.



Installation and Maintenance Instructions for JXL Couplings

This guide is for the installation of JXL couplings when a bellhousing is not used and covers the assembly of the coupling individual components.

Ensure each flange is clean. Fit each flange to their respective shafts. Line-up coupling flanges by checking dimensions between flange faces at 90° intervals and by using a straight edge across the outside diameter of flanges at 90° intervals. If possible a dial test indicator may be used to give accurate details of alignment. The flanges should be aligned to within the following tolerances noting that where one misalignment is present then the others must be reduced proportionally. **Careful alignment will extend coupling life.**

Parallel Misalignment

JXL 25 JXL 32	JXL 42 JXL 65	JXL 80 JXL 120	JXL 148 JXL 160	JXL 170 JXL 240	JXL 270 JXL 340
0.12	0.25	0.37	0.50	0.62	0.75

Angular Misalignment

All couplings, plus or minus 0.375° per hub maximum, 0.75° total.

Axial Misalignment

All couplings plus or minus 50% of flange gap (dimension C)

When the coupling hubs are within the correct alignment fit the coupling pins, liners and resilient elements ensuring that each pin assembly has three washers fitted; one under the cap screw head and one at either end of the element. The pins should be fitted with the self locking nut adjacent to the resilient element. Where half or less number of pin assemblies are being used, all elements should be fitted into one flange. When all pin assemblies are fitted tighten the self locking nuts in pairs at 180° to each other to the correct torque.

Tightening Torques for JXL Resilient Couplings

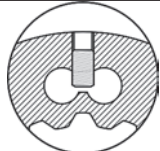
Coupling Size	Screw Size	Tightening Torque		Coupling Size	Screw Size	Tightening Torque		 L-Lock Screws	
		Nm	lb/ft			Nm	lb/ft		
25	M5	5.08	3.75	148	M16	187.00	138.00		
32	M5	5.08	3.75	160	M16	187.00	138.00		
42	M6	9.20	6.80	170	M16	187.00	138.00		
55	M6	9.20	6.80	190	M20	337.00	249.00		
65	M6	9.20	6.80	210	M20	337.00	249.00		
80	M10	41.00	30.00	240	M24	568.00	419.00		
90	M10	41.00	30.00	270	M30	1144.00	835.00		
100	M12	77.00	57.00	300	M30	1144.00	835.00		
120	M12	77.00	57.00	340	M30	1144.00	835.00		
								Grub Screw	Torque N m
								M10	30
								M12	50
								M14	70
								M16	120
								M20	200

Periodically check flange alignment and resilient elements for wear. Worn elements must be replaced. Misalignment must be rectified

Inspection and maintenance is the responsibility of the end user.

Note

All JXL couplings are capable of accepting a momentary overload of twice nominal torque and have an operating temperature range of -50°C to +105°C.



Type 1

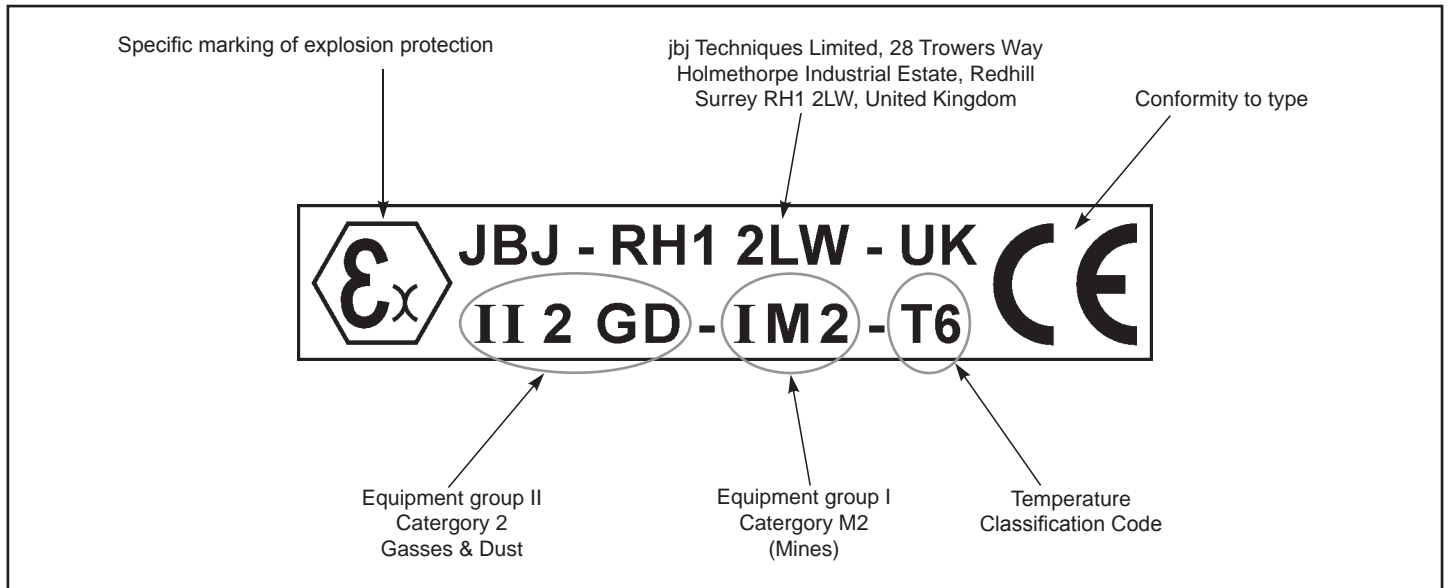

Type 3

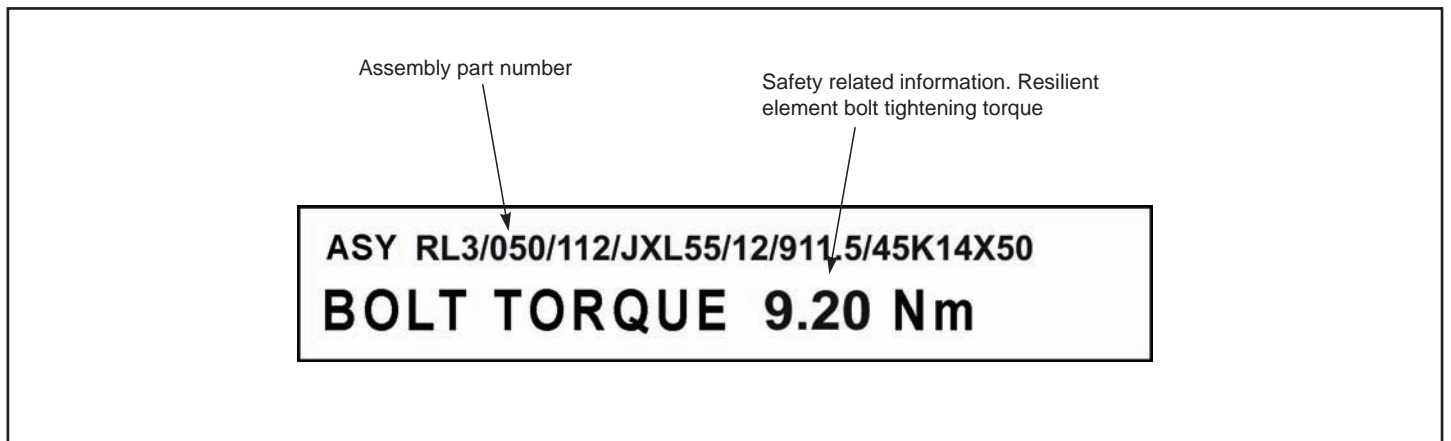

Type 4

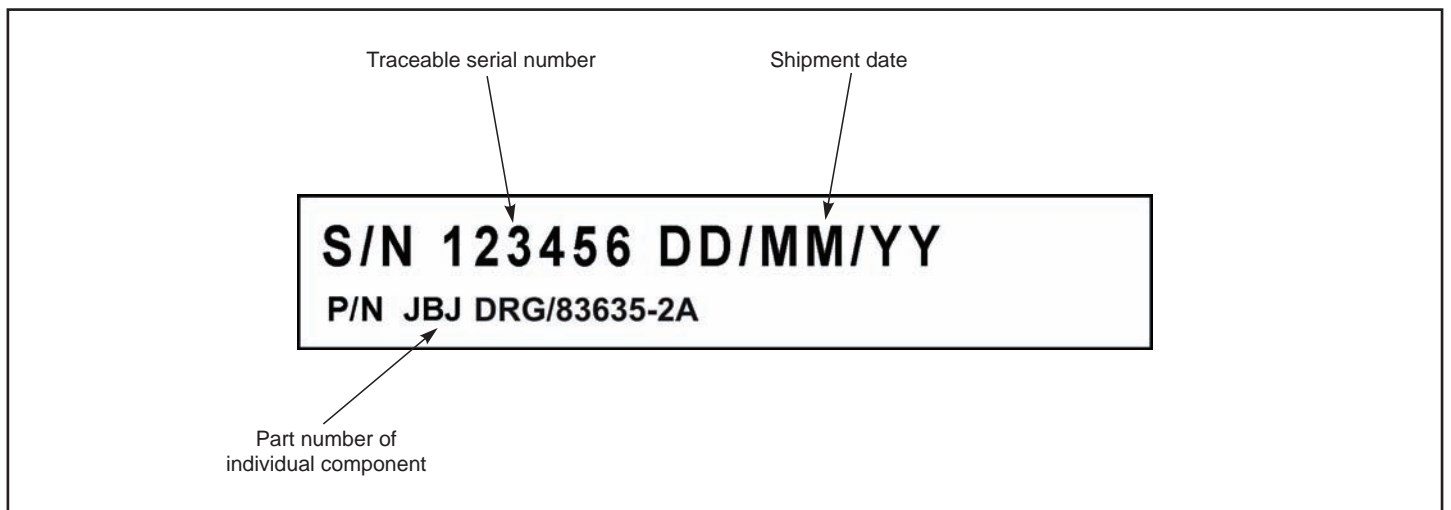



Label positions for JXL Flywheel Couplings & Engine Bellhousing.

Coupling

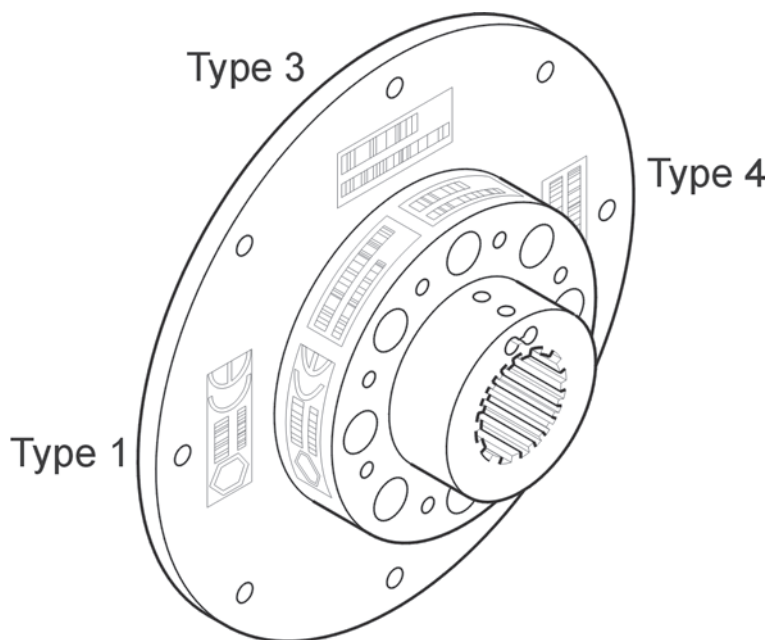

Housing

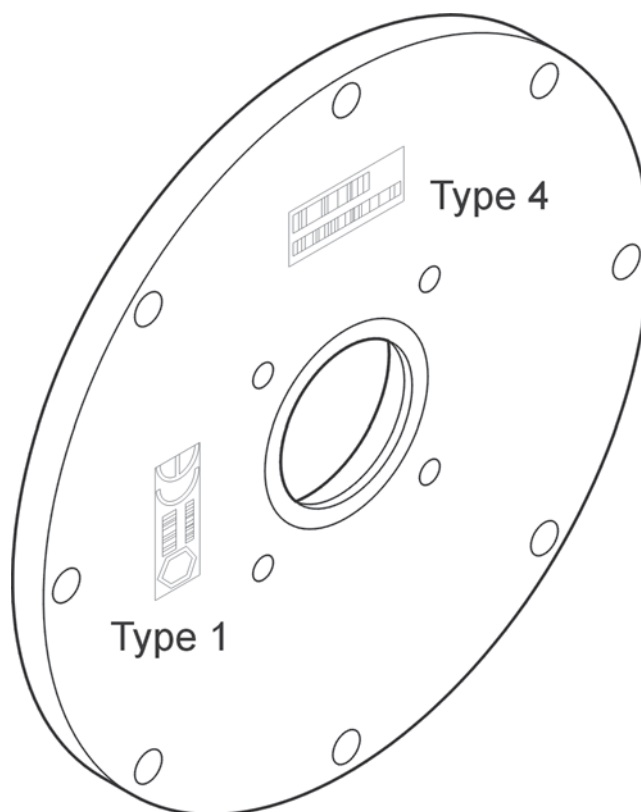



28 Trowers Way Holmethorpe Industrial Estate
Redhill Surrey RH1 2LW. United Kindom of Great Britain.

Telephone: +44(0)1737 767493 Fax: +44(0)1737 772041 Email: info@bjj.co.uk Website: www.bjj.co.uk